

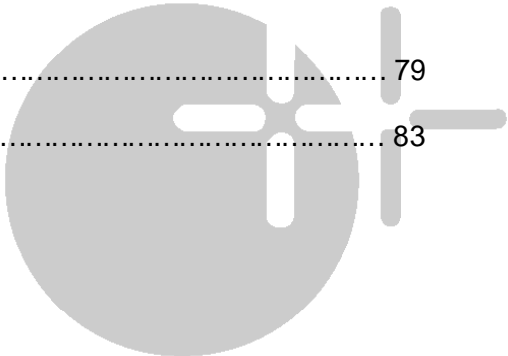

2004. 12.



.	1
.	5
1.	7
2.	(FAJ) ELF	9
3.	(FAJ) ELF() ...	10
.	가	31
.	...	37
1.	39
2.	53
.	77
1.	79
2.	83





■





•



1.

1)

(橫) , (縱)

- :

- :

(乾式) (濕式) 2가

- : ,

- :

- . .

가 .

.

ELF

ELF

FAJ

5



가

2)

(1) .



(2) .



(3) .

가



가



2. (FAJ) ELF

1)

ELF “Eco Line Flower”

,

FAJ 兼・産業 가

가

2) ELF



3. (FAJ) ELF()

FAJ

2001 1 5

. , 가
. 가 , 가 , , 가
. . . 가

1) 04

1	49,660	42,179	67.4
2	58,726	46,432	79.1%
3	78,853	45,906	58.2%
4	79,808	65,488	82.1%
5	81,340	63,100	78.0%
6	-	-	-
7	-	-	-
8	-	-	-
9	-	-	-
10	-	-	-
11	-	-	-
12	-	-	-
	348,387	263,105	74.9%

2) 02 - 03

	2002			2003		
1	24,624	19,368	78.7%	37,987	25,615	67.4%
2	26,847	18,696	69.6%	39,077	26,801	68.6%
3	40,738	31,802	78.1%	52,338	37,553	71.8%
4	43,083	35,457	82.3%	58,843	42,891	72.9%
5	46,265	36,469	78.8%	64,374	54,524	84.7%
6	38,952	33,228	85.3%	61,708	48,886	79.2%
7	46,658	36,160	77.5%	47,837	41,875	87.5%
8	31,333	29,926	93.3%	42,016	36,450	86.8%
9	40,368	30,856	76.4%	47,765	69,780	146%
10	45,024	32,497	72.2%	61,855	38,256	61.8%
11	45,124	36,831	81.6%	57,217	51,003	89.1%
12	38,029	28,148	74.0%	53,103	47,528	89.5%
	467,045	368,738	79.0%	624,117	521,191	83.5%

3) 04. 4 - 5

	ELF /	
	4	5
	36.4%	38.8%
	90.3%	89.5%
	87.0%	87.0%
	12.4%	16.9%
	29.9%	32.3%
	77.0%	71.6%
	69.2%	67.5%
	47.8%	50.8%
	43.7%	39.8%
	79.1%	-
	67.4%	64.8%
	76.2%	-
	18.3%	-
	62.1%	-
	17.4%	-
	-	14.5%

4)

가
.
가 가
 가 가
 가
 .
 ELF

5) 가



6) ELF

- . ,

- . ELF

- ELF

PP

- ,

. . 가

- 가

7) ELF

ELF

CF-240

CF-240 (本体)

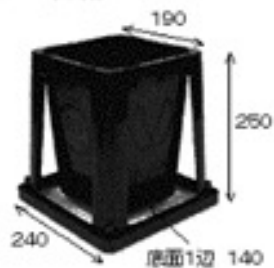

CF-241 (付屬)

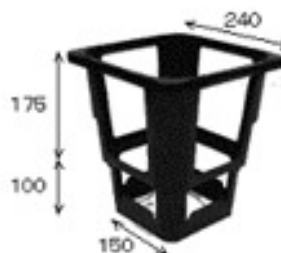

CF-245

CF-245 (本体)



CF-400

CF-400 (本体)

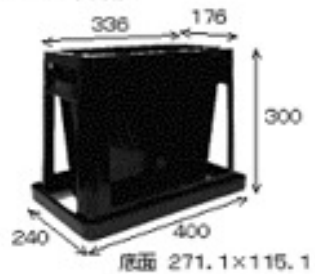

CF-401 (付屬)

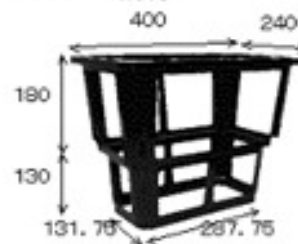

数字はバケット寸法(mm)

(1) ELF

A

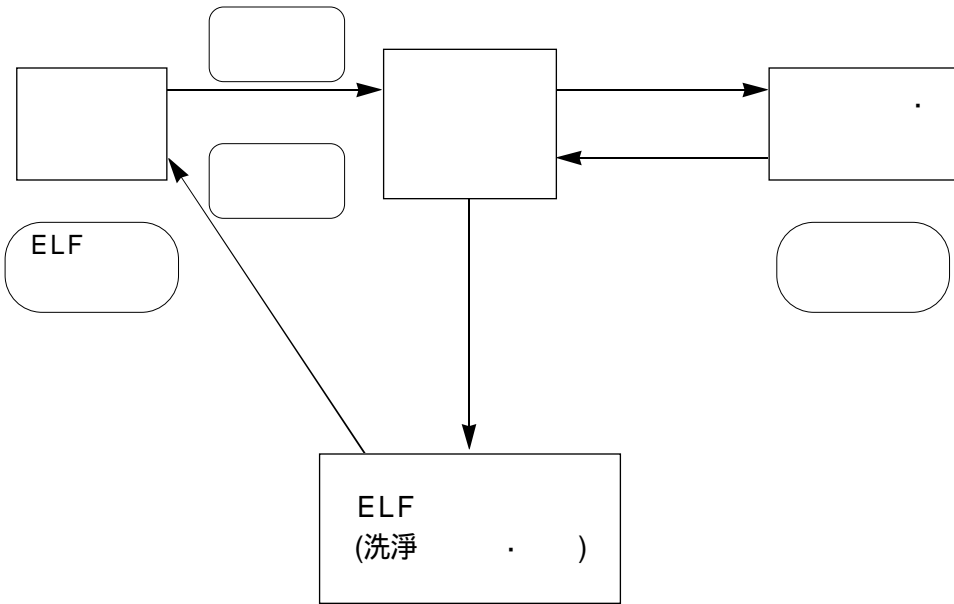

ELF

- ELF

- ELF

(

, T-Bag

가

가)

ELF

(

)

ELF

가

- ,

「T-Bag」

-

ELF

가

(,

가)

バケタタイプ	使用料(円)	
CF-240	A地区	100
	B地区	110
	C地区	120
CF-241	A地区	40
	B地区	40
	C地区	50
CF-245	A地区	110
	B地区	120
	C地区	130
CF-400	A地区	140
	B地区	150
	C地区	160
CF-401	A地区	80
	B地区	90
	C地区	100

T - Bag ELF

ELF A

. ELF

. ELF ELF A

-

-

ELF ELF A

ELF 가 ELF ,

가 ELF .

(3) ELF

가

가

- CF - 240() • CF - 241()
- CF - 400() • CF - 401()

가

가

- CF - 240() • CF - 241()
- CF - 400() • CF - 401()

가

- CF - 240()
 - CF - 400()
 - CF - 245()
-

ELF

① CF-240(本体)・CF-241(付属)使用①



CF-400(本体)・CF-401(付属)使用①



② CF-240(本体)・CF-241(付属)使用②



CF-400(本体)・CF-401(付属)使用②



㊦ CF-240(本体)使用



㊦ CF-245(本体)使用



㊦ CF-400(本体)使用



(4) T-Bag

ELF

A

ELF

T-Bag

- T - Bag
- ELF
-
- ELF
- T - Bag
- ELF T - Bag
- 가 , ,

- T - Bag 1 1
- CF - 240 : 1 T - Bag 1
- CF - 245, CF - 400 : 2 T - Bag 2

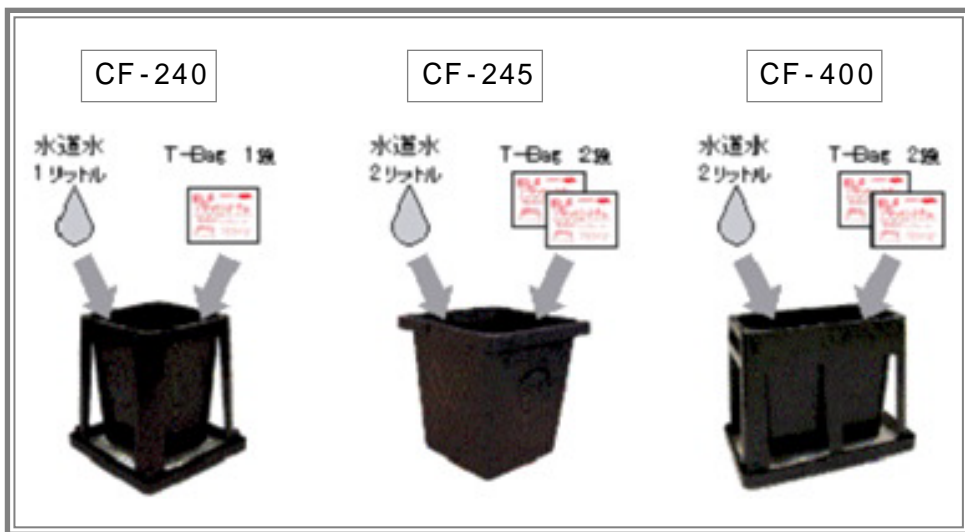

10) ELF BouquetMaker()

ELF BouquetMaker(, ELF B)
가 , 가 가
가 가
.
가

(1) ELF B

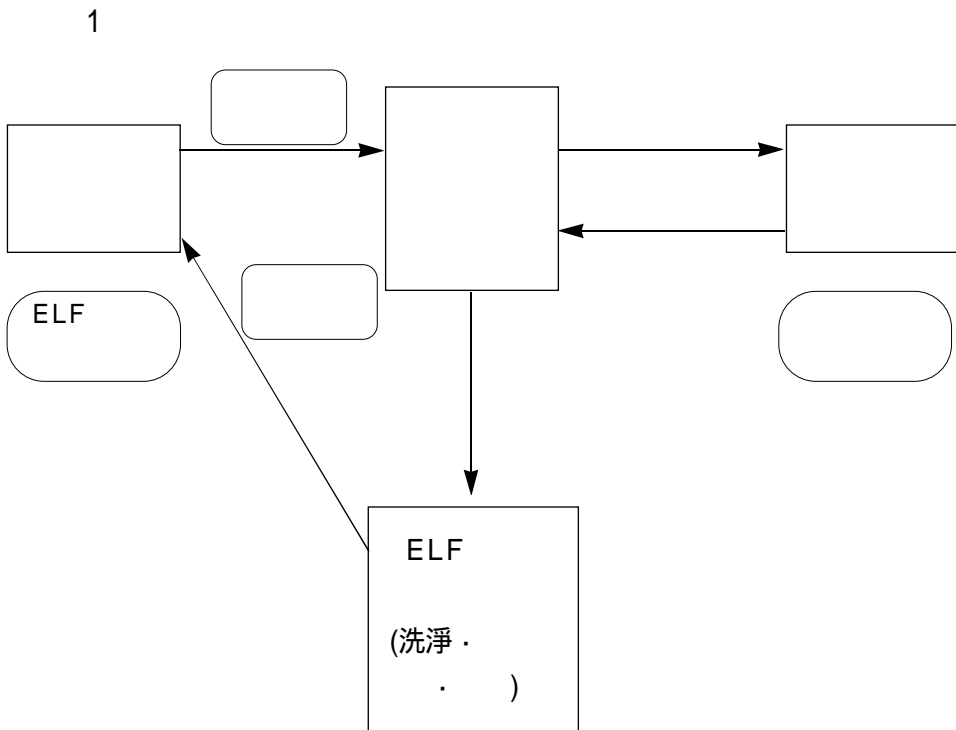

2

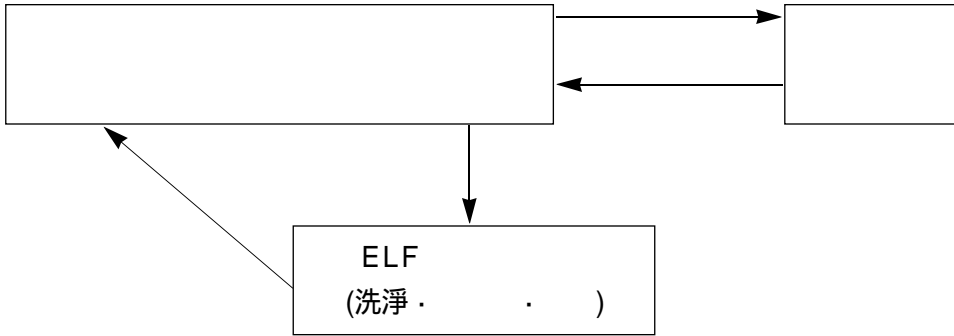

(2) ELF

B

가

- 가 ELF B ELF

- 가 ELF

가

ELF

- ELF B 가 ELF

ELF

- ELF

ELF

- ELF .
ELF
ELF . ELF
什器 ELF 가

(3) ELF

가 가
• CF - 240 () • CF - 241 ()
• CF - 400 () • CF - 401 ()

가
• CF - 240 ()
• CF - 400 ()
• CF - 245 ()

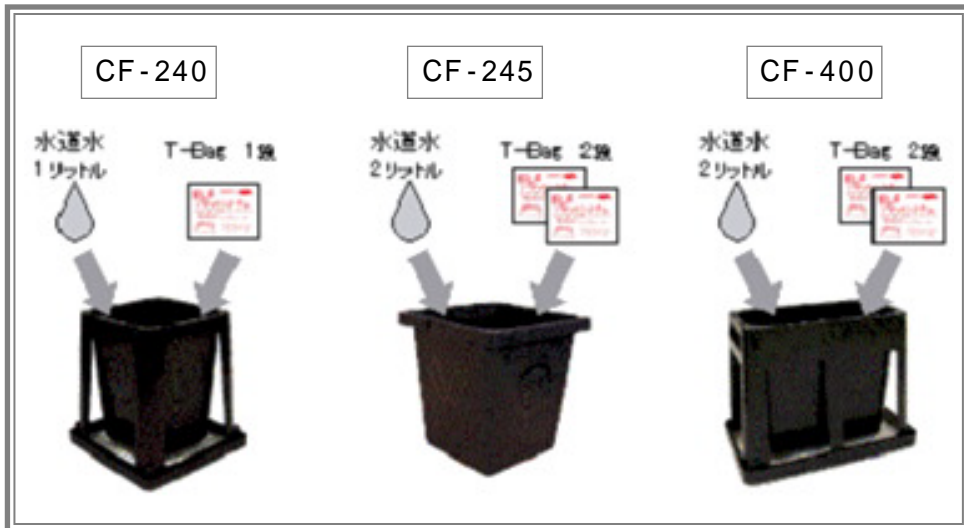

.

가



, ,

.

,

,

,

가

,

,

,

,

,

『

』

,

가

-

가 30% 가

가

3

,

가 ,
(,
,)
, , ,

가 가 , 가

가 가

,

가

가

가

가 가



▪



1.

1) ()

가

(1)

, ,

-

, ,

-

가

-

가 ,

-

(2) .

-

-

가 .

, STS, 糖

-

-

STS

STS (

100g 2~5 μ mol)

. STS 가 10mmol/l(mM), 100mmol/l, 200 mmol/l

가

- 多花性 糖

STS	, ,
STS+	, ()
STS+	,
STS+	, ,

: ,

- 가

가 가

-
- 10 , .
- 10 ~15 .

(3) (調整) · (選花) · (結束)

- , 25 ,
- 20 가

- 가

- . .
- . . . (導
- 管) 가 가 가 .

(切口)가

-

.

.

(4)

-

가

,

가

-

가

,

.

(切口)

-

가

.

가

가 가 .

가

- , ,

가 .

[]

- 가

•

•

가 5cm

가

(5) .

-

10

,

10~15

-

,

가

.

가

2)

(1)

.

가

-

,

.

가

-

가

.

(2)

- 가 가
10 , . 10~15
- 가
가 가 가 가
가 가

3) (.)

(1) . .

- 가 가
가
- 10 , . 10~15

- (荷受),

(2)

-

(3)

-

4) 가

(1) 가

-

-

10~15

,

10 , .

10~15

-

(2)

-

5)

(1)

-

(2)

- 가

-

-

가

-

가

(3)

-

가

가

가

-

가

-

1

-

가

가

10

,

10~15

-

-

가

가

(4)

- 가

- , 가
가

- 가 .

- 가 .

- 가

· , ·

·
가 가 가 .

-
가 가 .
가 ,

-
· , ·

- 가 가 . 가

- 가 .

가 ,

(2)

()

,
-

가

.
가

,

.

- 가

- 5~10

· ·

가

가

-

가

, 가

가

.

- 5

- 1~2 3~4

가

가 가 ,

가

- 5 가

(.)

. .

가

가

- 5 .

5.

-

. 가 가

- 5 . 가

5

- 가

- 가 .

. 15

,

- 가

2)

(1)

0.1ppm

菱凋()가

22

「黒花」가

가

가

(2)

()

-

-

가

-

(催花)

,

.

, STS,

-

STS

糖

- STS

0.2mM
STS가

6~12

,

STS

. 0.2mM
가 .

25%

가 24

가 .

- 가 10~15

· ·

- 가 가 가 가
가 , 가 가

- 1~2%
가 .

.

- 5

[]

(催花) (黑花)
- (小花)가
가 (黑花)가 .

가

-

催花

1~2

(STS 가)

2% + (가 , 가)

20~22 (40W 2) 催花 .
가 . (小花柄) (徒長)

3~5

- 5 가

(.)

. .

가

가

- 5 .

-

가

가

-

- 5

.

-

가

가

.

,

,

- 3 1 3 1

가

-

, 開藥 가

,

.

, STS

- 0.1~0.2mM STS , . 60

- 0.1~0.2mM STS 4% 가

STS

-

. .

가

가

-

가

.

가

가

.

- 10~15

.

- 10 ~15 가 .

가 . 가

(.)

. .

가

가

- 10~15

- 가 (菱凋)
가

-

,

-



1.

, 가 ,

가 . 2003

가 가

가

가

가

가 ,

, 가

,

가 .

가
, 가
가
가 . 가
가
가 . 가
가 가

2)

가
,

-

- 가 .
 , 가

3)

(: , %)

1996	9.6	0.17%	7.7	1.62%
1997	10.4	0.18%	8.5	1.73%
1998	11.2	0.20%	9.5	1.99%
1999	14.7	0.26%	9.1	1.88%
2000	19.5	0.35%	12.7	2.75%
2001	34.5	0.63%	20.2	4.48%
2002	56.5	1.04%	34.6	7.93%
2003	84.1	1.59%	39.4	9.51%

:
: ()

, 가

4)

M N

- : , ,
- 2001 . 가
- 가가 2003
- 3 .

O P

- : , , , 가
- 가 JA 가

2.

2010 35%

ELF

FAJ

5

가

가

1.6%)

3.6% (

ELF()

가

232 aT

: (02) 6300-1381~5

: (02) 6300-1609

: www.afmc.co.kr www.kati.net

